

National Free
Service Hotline

400-1020-858

swoda®

Suzhou Swoda Elevator Co.,Ltd

It changes your life by good spaces, high quality fulfills classics.

SUZHOU SWODA ELEVATOR CO.,LTD

Add: Building 1, No. 8, Jianye Road, Changshu Economic Development Zone,
Jiangsu, China.

Tel: 86-0512-52062565 Fax: 86-512-52261883

web: www.swoda-elevator.com

E-mail: sales@swoda-elevator.com

This book is a general information publication, and we reserve the right to make changes to the product design and instructions at any time. Any word of sentence in this book, regardless of the illustration or drawing, regarding any product and its purpose and quality, No responsibility shall be assumed for the expression or modification of any information in this book. This book is based on the actual contract. Due to limitations in the printing process, the actual processed colors may differ slightly from this book, and the final shape can be determined based on the actual material and color sample.

2024 Edition

2024
Enabling
Future prospects

Company profile

We founded in March 2010, specializing in manufacturing, selling, installing, repairing and maintaining elevators, escalators and moving walks.

Our factory is located in Changshu Economic Development Zone, which is a state level development zone. We have transportation facilities with good advanced geographical positions, near Shanghai.

Our factory covers an area of more than 35000 square meters with more than 20000 square meters workshop, over 8000 square meters office building. 90m high comprehensive elevator test tower can test maximum speed 7.0m/s elevators. The main products cover passenger elevator, observation elevator, hospital elevator, freight elevator, home elevator, automobile elevator, small machine room elevator, machine roomless elevator, escalator, moving walk, dumbwaiter and so on.

We can produce more than 6000 sets various elevators and escalators one year.

The product technological standard has reached the advanced international level.

It will become motive power of the sustainable business developments through the superior service, well-developed design, consummate technology and outstanding quality.

Company History

In 2001, Huasen Import and Export Company was established to do elevator export trade.

In 2010, Suzhou Schneider Elevator Co, Ltd was established to do elevator production and sales business.

In 2024, our company is renamed Suzhou Swoda Elevator Co, Ltd.

swoda®

Advanced technology

Control system: highly integrated Intelligent control system

Micro-computer control system + high-speed bus module = intellectual elevator control system.
Real-time monitor of closed-loop control functions, instant error correction, centralized dispatch / control of elevator group.
Wide application range, speed can fulfill 7m/s, 63 floors landing, 8 units elevator group control.

01

Best running curve

Curve generator can accurately measure the car position with real-time calculation of the best running curve. It brings about the more smoothly elevator running. It reduces the delivery time and enhances the leveling accuracy. It offers the more superior and comfortable travel.

02

Efficient management system

Dispatch system can precisely judge the changing transport system load and dynamic traffic flow. It sends out the effective dispatch command. It lowers down the stop times. It also reduces the passengers' waiting time and enhances the travel experience.

03

Energy

Energy re-generating system converts the elevators' gravitational potential energy to electric energy. It outputs the building's power grid for re-use with effective dispatch system. It reduces the unnecessary start and brake. It cuts down the energy consumption.

04

Cozy

It quickly responds the passengers' calling. It ensures the smooth elevator operation through digital controller and the advanced variable frequency driver. It guarantees the running quality by closed-loop vector control drive technology. It is not affected by any load changes.

05



The demeanor of a wise man stems from its connotation

Swoda serial passenger elevator are modern intellectual elevators that integrate high-tech, intellectual and human centered properties into one, Swoda is engaged in improving innovation, research and development. It provides vertical urban traffic & transport with the more perfect solution plans. Human dream of vertical spaces becomes reality.

Passenger elevator



Small machine room passenger elevator

Machine roomless passenger elevator

Machine room passenger elevator

Compared with passenger elevator with machine room, small machine room passenger elevator applies the rational construction layout. Machine room is exactly the same as well area. It saves the machine room space. Meanwhile, it reduces machine room's peculiar outline influence towards the building. It can adapt to various buildings which get special construction requirements to the outlook. It thus decreases the construction cost.

Machine roomless passenger elevator

Machine roomless passenger elevator knows very well of environment-protection concept. It saves the energy and reduces the consumption. It also saves the building area and increases the design freedom. It fully displays green human-centered ideas. Compared with same load level geared elevator, it saves 25% of electric energy and 10% of building area.



External shaft elevator

Modular steel structure

It uses the fixed shape steel materials. It applies unique design and craft for making. Steel structure is designed and manufactured by the professional teams. It can adapt to various complex building structures. It perfectly combines with elevator devices.

Entry mode

Swoda serial reinstalled elevators get the multiple site pre-installation plans. It can have flexible application upon different site conditions. It can be individually tailor-made as per the owners requirements. It thus satisfies different home decoration demands in various buildings.



Flat layer entry, straight platform

Flat layer entry,
side platform



Flat layer entry,
double span ear platform

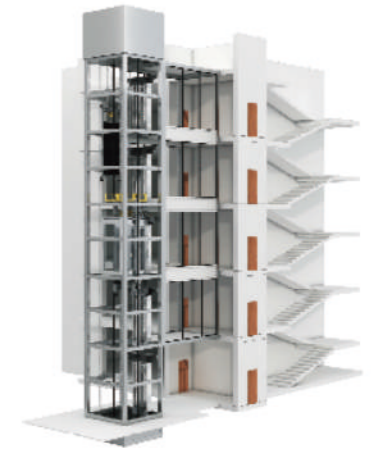

Flat layer entry,
no platform direct
connection



Flat layer entry,
no platform direct
connection
(through door)



The half layer entry,
straight platform



The half layer entry,
side platform



Passenger elevator car decoration



SS-CA



Standard

- Ceiling.....Hairline stainless steel, acrylic lamp decoration, downlights
- Car wall.....Hairline stainless steel
- Handrail.....None
- Floor.....PVC imitation marble
- Optional material.....Mirror stainless steel

Ceiling



CD101



CD102

Only applicable to deep lift cars



CD103

Only applicable to deep lift cars

Plastic jet color

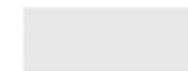

JG-Y05
(RAL7001)



JG-Y06
(RAL9003)

Landing door



SS-LD-01



SS-LD-02

First landing door hairline stainless steel, other doors painted steel.

Floor



FL-001



FL-002

Operation panel



CL-60C-H

Hairline stainless steel



ST-D30HC

Hairline stainless steel (without bottom case)

Passenger elevator car decoration

Standard collocation



SS-CD

Ceiling: Hairline stainless steel
Car wall: Hairline stainless steel,
Floor: PVC
Optional material : Painted steel

Ceiling



CD101



CD102



CD103

Plastic jet color



JG-Y05 light gray



JG-Y06 white

Landing

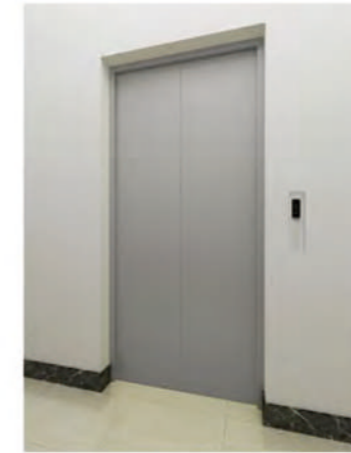

SS-LD-01

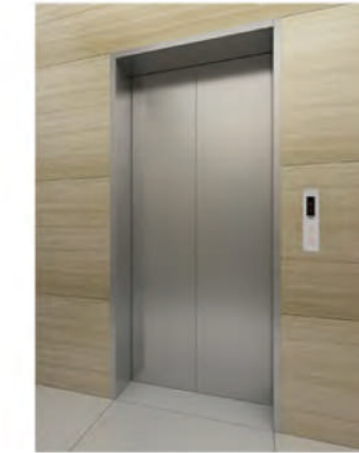

SS-LD-02

First landing door hairline stainless steel, other doors painted steel.

Floor

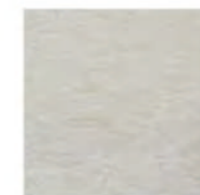

FL-003



FL-004



FL-007

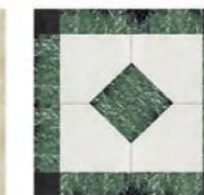

FL-008

Car operation panel



CL-60C-H



ST-D30H

Passenger elevator car decoration



SS-C10



Ceiling.....Hairline stainless steel, acrylic , downlights
Car wall.....Hairline stainless steel, mirror stainless steel, mirror etching stainless steel
Handrail.....Hairline stainless steel round handrail
Floor..... PVC



SS-C12



Ceiling.....Mirror stainless steel with acrylic craft board
Car wall.....Hairline stainless steel, mirror etching stainless steel
Handrail.....Hairline stainless steel flat handrail
Floor..... PVC



SS-C11

Ceiling.....Hairline stainless steel, acrylic , downlights
Car wall.....Black mirror stainless steel, mirror stainless steel, mirror etching stainless steel
Handrail.....Hairline stainless steel flat handrail
Floor.....PVC



SS-C13

Ceiling.....Hairline stainless steel frame, acrylic craft board
Car wall.....Hairline stainless steel, mirror etching stainless steel
Handrail.....Hairline stainless steel round handrail
Floor..... PVC



Passenger elevator car decoration



SS-C15



Ceiling.....Golden mirror stainless steel frame with acrylic craft board
Car wal.....Golden hairline stainless steel, golden mirror etching
Handrail.....Golden mirror stainless steel + wooden
Floor.....PVC



SS-C18



Ceiling.....Hairline stainless steel, acrylic
Car wall.....Wood grain decoration veneer steel, mirror stainless steel
Handrail.....None
Floor.....PVC



SS-C16



Ceiling.....Golden mirror stainless steel, acrylic , downlights
Car wall.....Golden mirror stainless steel, golden mirror etching stainless steel
Handrail.....None
Floor.....PVC



SS-C19



Ceiling.....Mirror stainless steel, acrylic LED downlights, decoration veneer steel
Car wall.....Wood grain decoration veneer steel, mirror stainless steel
Handrail.....Hairline stainless steel round handrail
Floor.....PVC

SEL Passenger elevator construction parameters

Hoistway vertical section

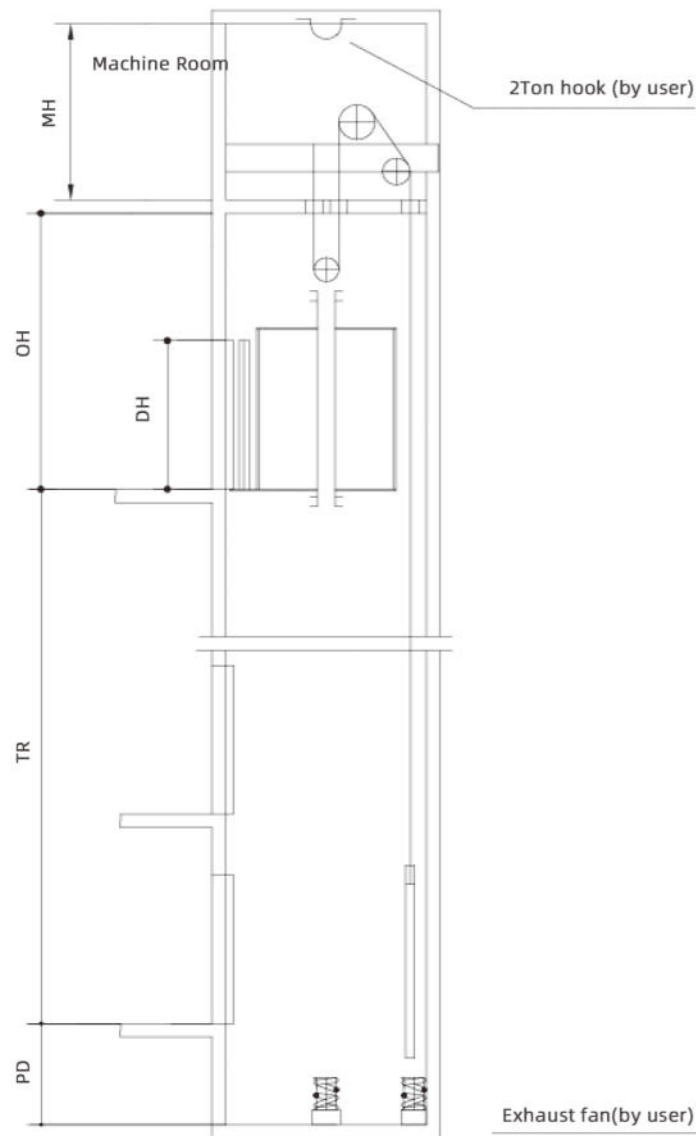

Hoistway plan layout

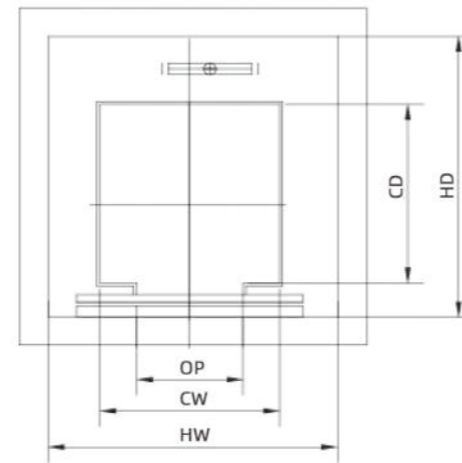

Machineroom plan layout

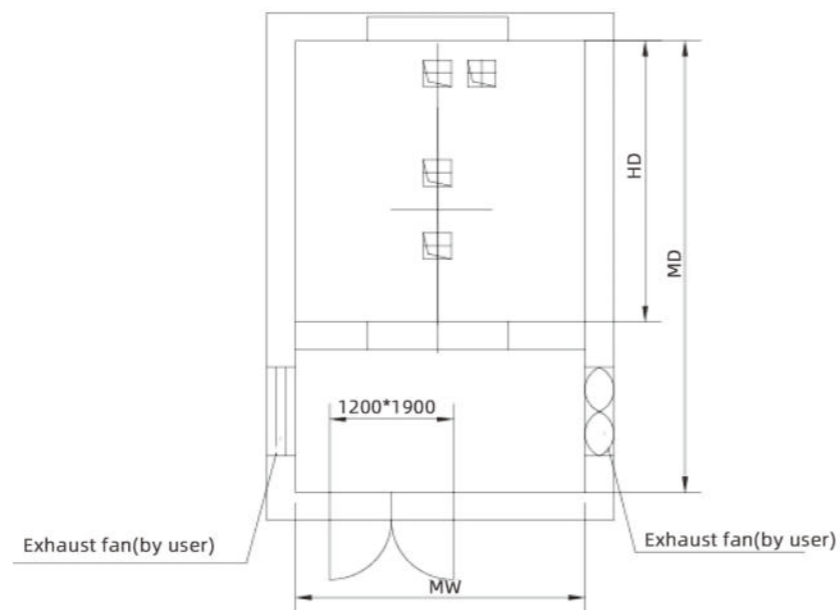

SEL Passenger Elevator Basic Technical Specification Table

Model	Loading kg	Speed m/s	Power kw	Car net size(mm)			Hoistway net size(mm)				Machine room net size(mm)			Max floor station	Max stroke (m)
				CW	CD	OP	HW	HD	PD	OH	MW	MD	MH		
SEL450	450	1.0	4.1	1100	1100	800	1800	1750	1400	4400	1800	1750	2500	14	45
		1.5	6.2						1500	4500					
SEL630	630	1.0	4.1	1100	1400	800	1800	2050	1400	4400	1800	2050	2500	14	45
		1.5	6.2						1500	4500					
		1.75	7.2						1600	4600					
SEL800	800	1.0	5	1350	1400	800	1900	2050	1400	4400	1900	2050	2500	14	45
		1.5	7.8						1500	4500					
		1.75	9						1600	4600					
		2.0	9.8						1700	4600					
SEL1000	1000	1.0	6	1600	1400	900	2150	2050	1400	4400	2150	2050	2500	14	45
		1.5	10						1500	4500					
		1.75	11.7						1600	4600					
		2.0	12.3						1700	4600					
SEL1250	1250	1.0	8.2	1950	1400	1000	2250	2150	1400	4200	2250	2150	2500	14	45
		1.5	12.3						1500	4300					
		1.75	14.3						1600	4400					
		2.0	16.3						1700	4500					
SEL1600	1600	1.0	10.5	1950	1750	1000	2550	2500	1400	4200	2550	2500	2500	14	45
		1.5	15.7						1500	4300					
		1.75	18.3						1600	4400					
		2.0	20.9						1700	4500					

The schematic drawing of civil work is for reference only

SEL(MRL) Machine roomless passenger elevator construction parameters

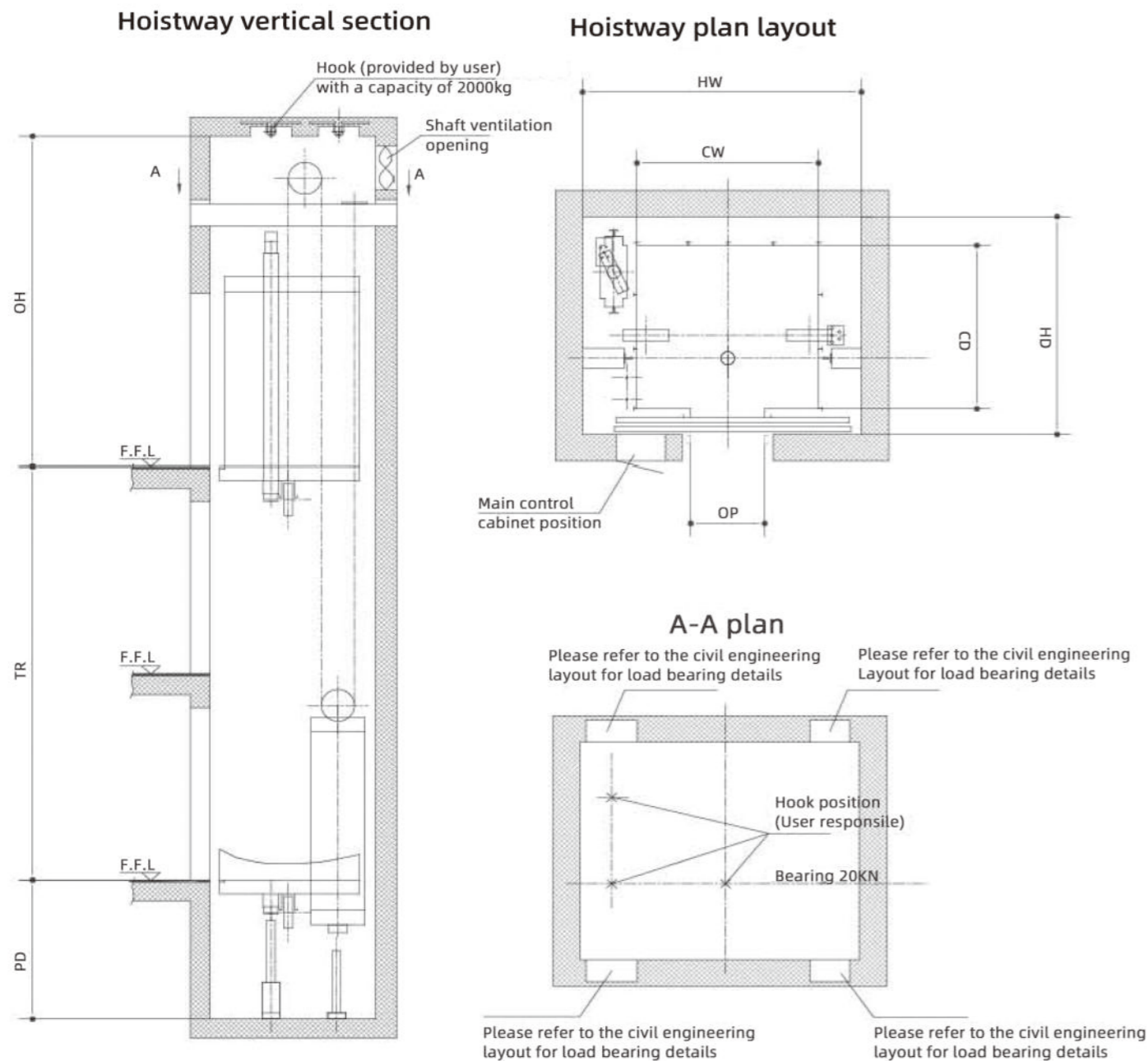

SEL(MRL) Machine Roomless Passenger Elevator Basic Technical Specification Table

Model	Loading kg	Speed m/s	Power kw	Car net size(mm)			Hoistway net size(mm)				Max floor station	Max stroke (m)
				CW	CD	OP	HW	HD	PD	OH		
SEL(MRL) 450	450	1.0	4.1	1100	1100	700	1900	1650	1500	4200	14	40
		1.5	6.2						1600	4300	20	60
SEL(MRL) 630	630	1.0	4.1	1100	1400	800	1900	1900	1500	4200	14	40
		1.5	6.2						1600	4300	20	60
		1.75	7.2						1700	4400	24	70
SEL(MRL) 800	800	1.0	5	1350	1400	800	2150	1900	1500	4200	14	40
		1.5	7.8						1600	4300	20	60
		1.75	9						1700	4400	24	70
SEL(MRL) 1000	1000	1.0	6	1600	1400	900	2400	19000	1500	4200	14	40
		1.5	10						1600	4300	20	60
		1.75	11.7						1700	4400	24	70
SEL(MRL) 1250	1250	1.0	8.2	1400	1950	1100	2600	2500	1500	4600	14	40
		1.5	12.3						1600	4700	20	60
		1.75	14.3						1700	4800	24	70
SEL(MRL) 1600	1600	1.0	10.5	1750	1950	1100	2850	2500	1500	4600	14	40
		1.5	15.7						1600	4700	20	60
		1.75	18.3						1700	4800	24	70
		2.0	20.9						1800	4900	30	90

The schematic drawing of civil work is for reference only

It relaxes your heart and soul, set your dream to a long voyage.

Fine and exquisite observation elevator can enhance the buildings' grade. It highlights the whole building. Swoda serial panoramic elevator is a mobile scene. It has delicate visual aesthetics and the perfect & comfortable travel. It applies new modern materials, novel styles of fully computerized and vector type variable frequency speed governor (VVVF) control technology. It combines with data network system, modular structure, the latest machining craft & technology for manufacture.

Panoramic elevator

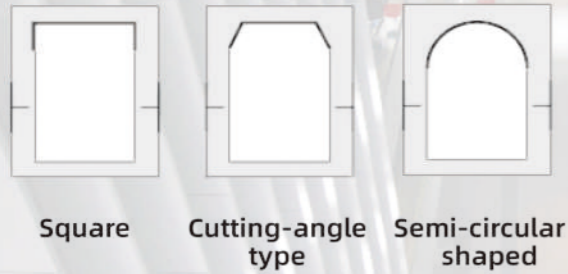

Selection of various car shapes

According to different styles of buildings, it can choose different car shapes. It adds infinite charm to the building during the travel process.

Selection of all glass and half glass car

It supplies full glass, glass rear-wall. Partial glass side-wall and full-glass side-wall configurations etc. It satisfies the clients' decoration requirements.

Multiple comprehensive solutions

According to modern city space requirements, it offers machine room-less plan and small machine room plan.

SEG panoramic elevator construction parameters

Hoistway vertical section

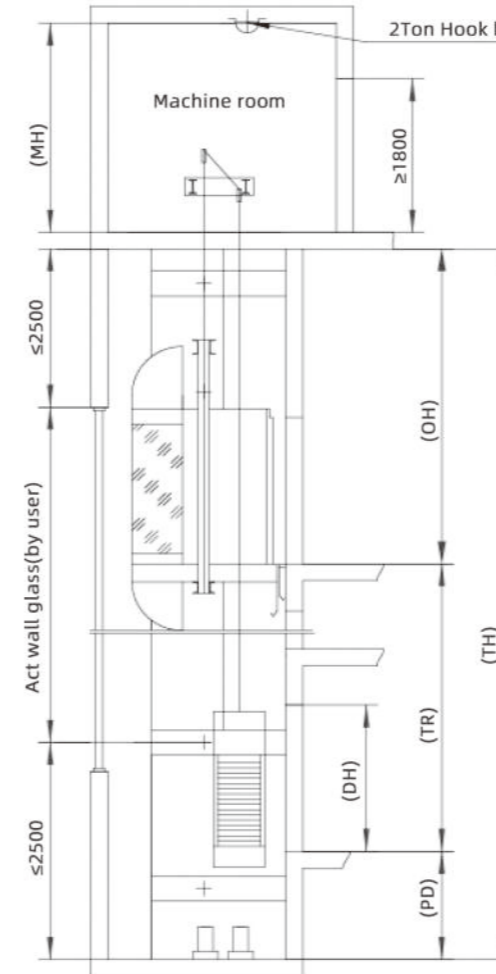

Machine room plan layout

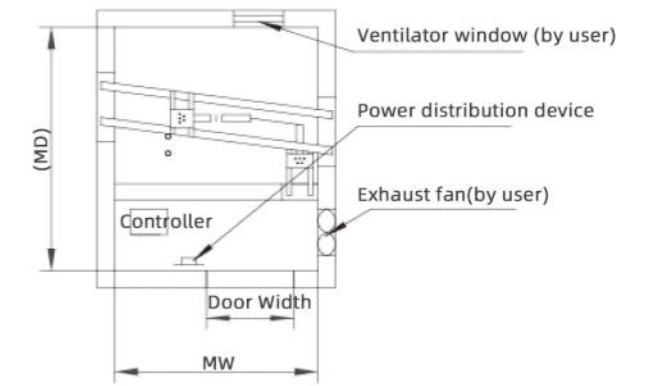

Hoistway plan layout

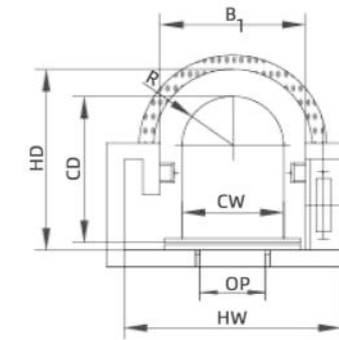

Hoistway plan layout

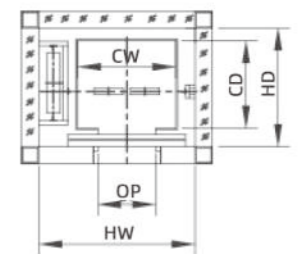

SEG Panoramic Elevator Basic Technical Specification Table

Model	Loading kg	Speed m/s	Power kw	Car net size(mm)			Hoistway net size(mm)				Machine room net size(mm)			Max floor station	Max stroke (m)
				CW	CD	OP	HW	HD	PD	OH	MW	MD	MH		
SEG630	630	1.0	4.1	1200	1750	800	2800	2250	1500	4300	2800	3500	2500	14	45
		1.5	6.2						1600	4400				20	65
		1.75	7.2						1700	4500				24	75
SEG800	800	1.0	5	1400	1800	900	3000	2300	1500	4300	3000	3600	2500	14	45
		1.5	7.8						1600	4400				20	65
		1.75	9						1700	4500				24	75
		2.0	9.8						1800	4600				30	90
SEG1000	1000	1.0	6	1400	2100	9000	3000	2600	1500	4300	3000	3800	2500	14	45
		1.5	10						1600	4400				20	65
		1.75	11.7						1700	4500				24	75
		2.0	12.3						1800	4600				30	90

The schematic drawing of civil work is for reference only

Panoramic elevator car decoration



SS-E23



- Ceiling.....Hairline stainless steel, acrylic
- Front wall.....Hairline stainless steel
- Side wall.....Hairline stainless steel,safety laminated glass
- Rear wall.....Safety laminated glass
- Handrail.....Hairline stainless steel round handrail
- Floor..... PVC



SS-E25



- Ceiling.....Paint steel,acrylic lighting decoration
- Front wall.....Hairline stainless steel
- Side wall.....Hairline stainless steel
- Rear wall.....Safety laminated glass
- Handrail.....Hairline stainless steel round handrail
- Floor.....PVC imitation marble

Panoramic elevator car decoration



SS-E21



Ceiling.....Hairline stainless steel, acrylic, downlights
 Front wall.....Hairline stainless steel
 Side wall.....Hairline stainless steel, laminated glass
 Rear wall.....Safety laminated glass
 Handrail.....Round hairline stainless steel tube
 Floor..... PVC imitation marble

SS-E22



Ceiling.....Hairline stainless steel, mirror strips, downlights
 Front wall.....Hairline stainless steel
 Side wall.....Hairline stainless steel, laminated glass
 Rear wall.....Safety laminated glass
 Handrail.....Round hairline stainless steel tube
 Floor..... PVC imitation marble

SS-E24



Upper and lower cover color.....RAL1024
 Ceiling.....Hairline stainless steel, acrylic lamp decoration
 Front wall.....Hairline stainless steel
 Side wall.....Hairline stainless steel
 Rear wall.....Safety laminated glass
 Handrail....Round hairline stainless steel tube
 Floor..... PVC imitation marble

SS-E26



Upper and lower cover color.....RAL1003
 Ceiling.....Hairline stainless steel, acrylic, downlights
 Front wall.....Hairline stainless steel
 Side wall.....Hairline stainless steel
 Rear wall.....Safety laminated glass
 Handrail.....Round hairline stainless steel tube
 Floor..... PVC imitation marble

Hospital elevator

The kind people love human beings. Swoda series hospital elevator conveys lift to the people in perfect details.

Swoda serial hospital elevator applies the advanced technology with broad car, smooth operation, rational design and convenient installation. It can hold hospital stretcher. It is used for emergency hospital channel. It gains more time for rescuing lives.



Special functions for the handicapped fulfill equal carrying in a harmonious space

Human-centered installation height is convenient for the disabled to freely enter into and exit from the elevators. Embedded installation saves the car space. It prevents from any scratch injury. Highly recognized Braille buttons are convenient for amblyopes. Furthermore, it has time-delay opening / closing functions- (optional). It can prolong the opening time for passengers to enter into and exit from the elevators.



SEB Hospital elevator construction parameters

Hoistway vertical section

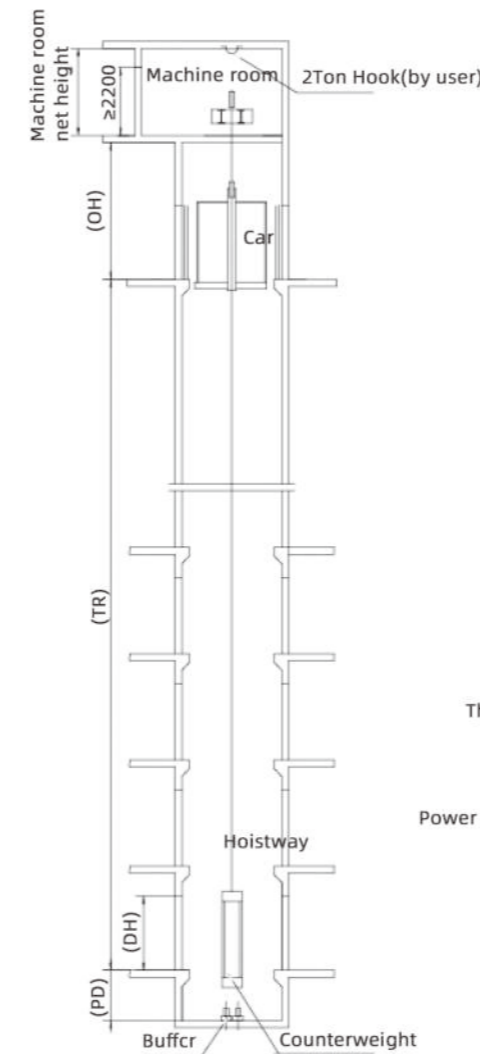

Hoistway plan layout

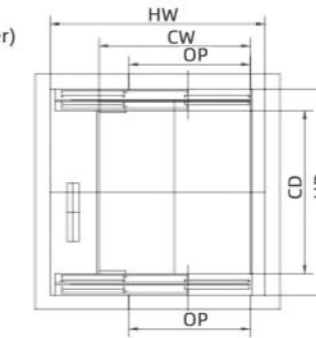

Hoistway plan layout

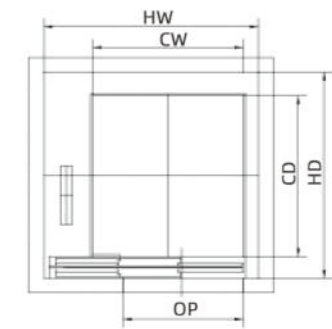

Machine room plan layout

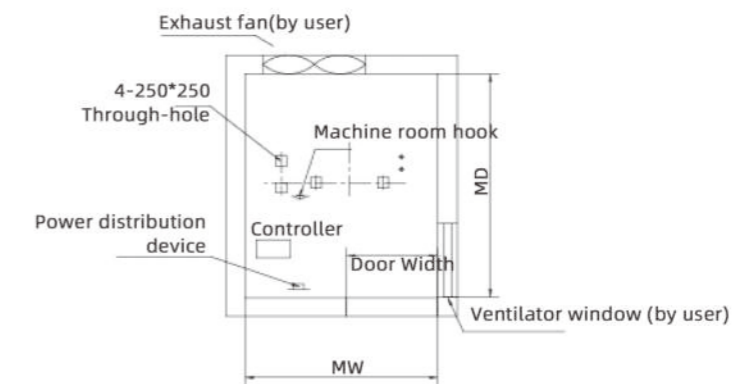

SEB Hospital Elevator Basic Technical Specification Table

Model	Loading kg	Speed m/s	Power kw	Car net size(mm)			Hoistway net size(mm)				Machine room net size(mm)			Max floor station	Max stroke (m)
				CW	CD	OP	HW	HD	PD	OH	MW	MD	MH		
SEB1600	1600	1.0	10.5	1400	2400	1100	2400	2800	1500	4500	2400	2800	2800	14	45
		1.75	18.3						1600	4500				24	78
SEB1600	1600 (opposite door)	1.0	10.5	1400	2400	1100	2400	2950	1500	4500	2400	2950	2800	14	45
		1.75	18.3						1600	4500				24	78
SEB1000	1000	1.0	6	1100	2100	900	2100	2550	1400	4000	2100	2550	2800	14	45
		1.5	10						1500	4100				25	75
		1.75	11.7						1600	4200				30	90
SEB1000	1000	1.0	6	1300	1800	900	2100	2250	1400	4000	2100	2250	2800	14	45
		1.5	10						1500	4100				25	75
		1.75	11.7						1600	4200				30	90
SEB1000	1000	1.0	6	1600	1500	900	2400	1950	1400	4000	2400	1950	2800	14	45
		1.5	10						1500	4100				25	75
		1.75	11.7						1600	4200				30	90

The schematic drawing of civil work is for reference only

Hospital elevator car decoration



SS-Y01



ST-DS

- Ceiling.....Hairline stainless steel, acrylic sheet, LED energy-saving downlights
- CabinHairline stainless steel
- Car door.....Hairline stainless steel
- HandrailHairline stainless steel flat handrail
- LightingLED downlights
- Floor.....PVC imitation marble (Standard)

● On transom Hall Position Indicator



HID-A122

7 segment code display



HID-A162

● On Wall Hall Position Indicator

Red dot



HID-A207

7 segment code display



HID-A209

● Hall Lantren



A401



A402



HHP 94

Jamb

Ground Floor

Typical Floors



Jamb: Wide Tapered With Transom



Jamb: Wide Tapered Wall mounted Transom



Jamb: Wide Tapered Without Transom



Jamb: Narrow Jamb Without Transom

Car operation panel



CL-60C-E
Mirror stainless steel

CL-60C-M
Mirror stainless steel

CL-60C-J
Titanium mirror stainless steel



CL-100C-A
Hairline stainless steel
(Integrated)

ST-L36H
Mirror stainless steel
(without bottom case)

ST-L37H
Titanium mirror stainless steel
(without bottom case)

Ceiling series



CD-001

Hairline stainless frame with acrylic top panel, downlights



CD-002

Hairline stainless frame, acrylic lighting cover, downlights



CD-003

Hairline stainless frame with acrylic top panel, downlights



CD-004

Hairline stainless frame, acrylic lighting cover, downlights



CD-005

Ti-plated stainless steel frame with acrylic top panel, downlights

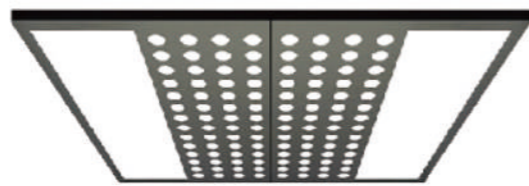

CD-006

Hairline stainless steel frame with multi-layer lighting board, acrylic lighting decoration



CD-007

Ti-plated stainless steel frame with acrylic top panel, checked



CD-008

Ti-plated stainless steel frame, dusting steel plate, downlights with inner lighting fixture



CD-009

Image flat top and middle hollow diamond-shaped transparent lamp post soft lighting design



CD-010

Steel plate spraying, rectangular hollow transparent lamp post, arch white organic transparent board soft lighting design



CD-011

Mirror stainless steel, image plate, LED downlights

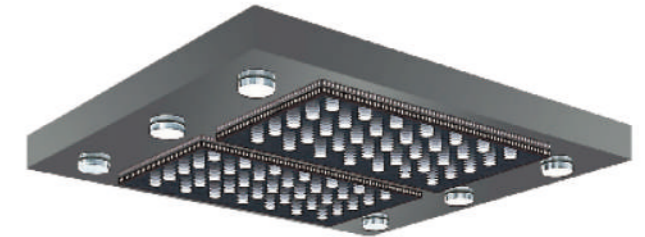

CD-012

Mirror stainless steel, laminated reflection with solid organic column lighting design



CD-013

Mirror stainless steel, double vault, central LED downlights



CD-014

Stainless steel titanium mirror hollow and white transparent plate, with aluminum alloy frame



CD-015

Hairline stainless steel, acrylic transparent plate, downlights



CD-016

Stainless steel mirror hollow plate, white transparent plate, diamond-shaped transparent lamp post soft light lighting design

Landing door series



SS-LD-02
Landing door:
Hairline stainless steel
Jamb: Hairline stainless steel



SS-LD-03
Landing door:
Mirror stainless steel
Jamb: Mirror stainless steel



SS-LD-04
Landing door:
Mirror stainless steel+glass
Jamb: Mirror stainless steel

Landing door panel series



SD-005



SD-102



SD-103



SD-104

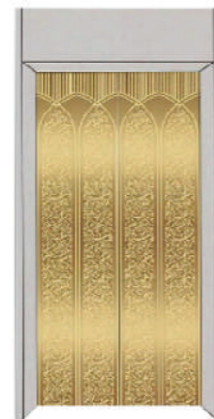

SD-105



SD-106



SD-107

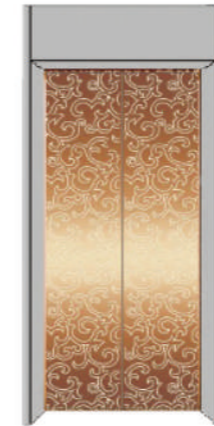

SD-108



SD-109



SD-110



SD-111

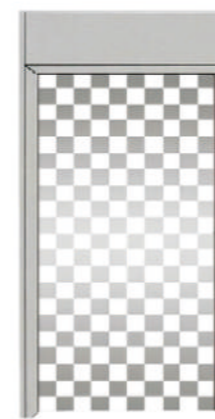

SD-112



SD-113



SD-114



SD-115



SD-116



SD-117



SD-118



SD-119



SD-120

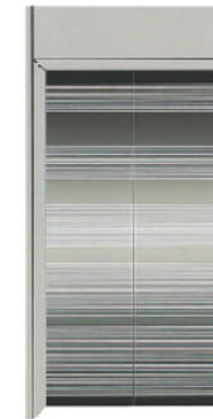

SD-121

Floor series

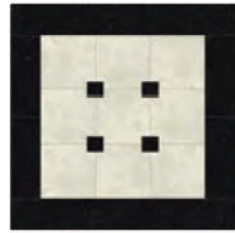

FL-009



FL-010

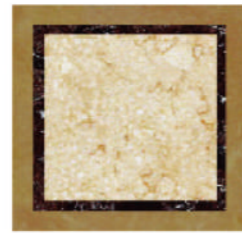

FL-011

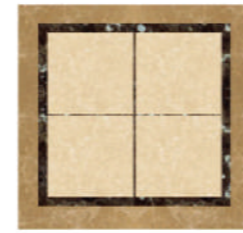

FL-012



FL-014



FL-015



FL-016



FL-017



FL-018



FL-019



FL-020

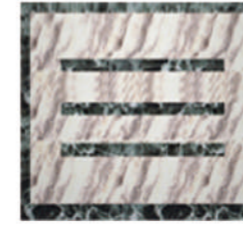

FL-021



FL-022



FL-023



FL-024



FL-025

Handrail series



JG-H001



JG-H002



JG-H003



JG-H004



JG-H005



JG-H006



JG-H007



JG-H008



JG-H009



JG-H010



JG-H011



JG-H012

Home elevator

Our boundlessly sweet efforts aim at protecting your interests heart and soul

Swoda serial home elevator lets you fully enjoy a cozy life with all-round comfortable travel, low noise, convenient installation. It fulfills your magical household environments with small covering area, none elevator well. It is safe and reliable. It gives a full use of your buildings. It is also the most ideal up / down traffic tool for the old, patents and disabled.

Four advantages of the human design

Environment-protection and energy-saving:
Power consumption of 220v or 380V voltage is equal to that of a fridge.

Product features: It can have no construction well, no pit. It is cozy and attractive.

Applicable occasions: Different styles and structures of villas

Style and outlook: It suits various kinds of decoration styles.



Center-opening

Side-opening

Manually operated door



SS-H201

CeilingHairline stainless steel,
acrylic decoration, LED downlights
Car wallHairline stainless steel,
mirror stainless steel
HandrailNone
Floor.....PVC imitation marble



SS-H203

Ceiling..... Golden mirror stainless steel,
acrylic decoration, LED downlights
Car wallGolden hairline stainless steel,
mirror stainless steel
HandrailNone
Floor.....PVC imitation marble

SS-H206



Ceiling..... Golden mirror stainless steel,
acrylic lighting
Car wall Golden mirror stainless steel,
safety laminated glass
HandrailNone
Floor.....PVC



SS-H210



Ceiling.....White painted surface,
black titanium edge
Car wall.....Wood and black titanium compose
Handrail..... Hairline stainless steel tube
(Optional)
Floor.....PVC

SS-H209



Ceiling.....Mirror stainless steel,
acrylic, LED downlights
Car wallMirror stainless steel,
wood grain decoration veneer steel
Handrail.....Hairline stainless steel round
Floor.....PVC



SS-H211



Ceiling.....Metal paint, mirror stainless steel,
LED lighting
Car wallMirror stainless steel, lamp strip
wood grain fireproof panel, decoration painting
HandrailNone
Floor.....PVC

SS-H212



Ceiling.....Rose golden mirror stainless steel,
acrylic white translucent panel, LED downlights
Car wall...Rose golden mirror-etched stainless steel,
rose golden mirror stainless steel,
rose golden hairline stainless steel
Handrail.....None
Floor.....PVC imitation marble



SS-H213



Ceiling.....Golden hairline stainless steel,
white light permeable panel, downlights
Car wallGolden mirror stainless steel, etching
HandrailGolden hairline stainless steel
Floor.....PVC imitation marble



Operation panel

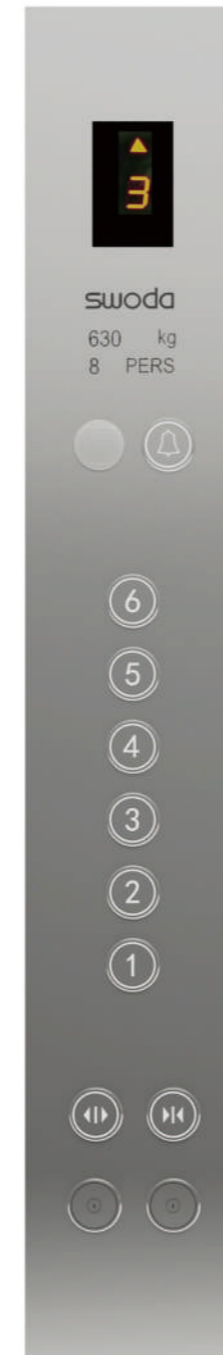

ST-L21C-F
Mirror stainless steel

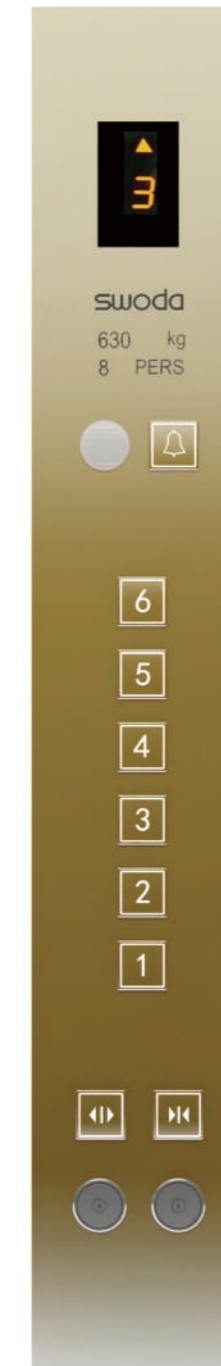

ST-L21C-FG
Titanium mirror
stainless steel

Touch screen
operation panel



TC-L10C

Call box



ST-L16H
Mirror stainless steel
(without bottom case)



ST-D15H
(Gold and silver)



ST-D15H
(Black silver)



ST-D12H
(Black silver)



ST-D12H
(Black gold)

SEJ Traction type home elevator construction parameters

Hoistway vertical section

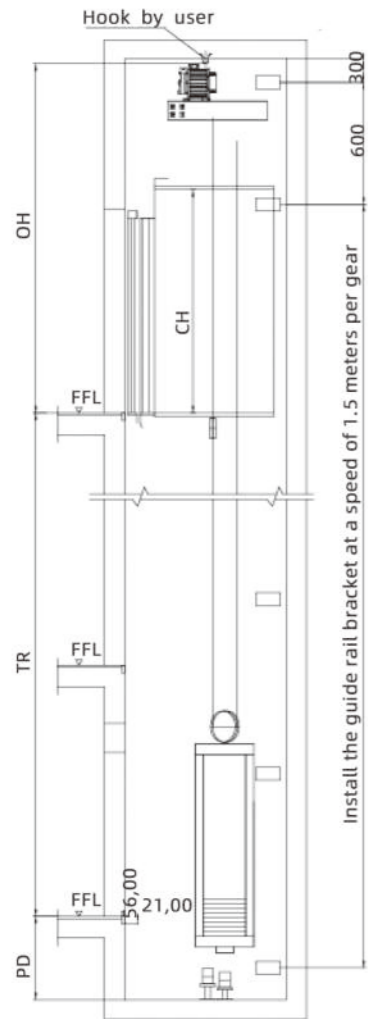

Hoistway plan layout

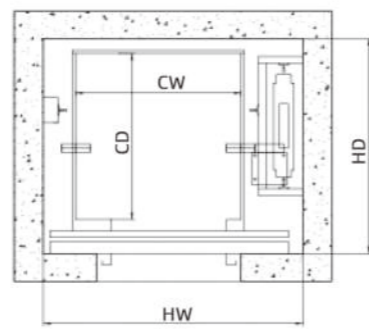

Drawing of reserved holes at inlet and outlet

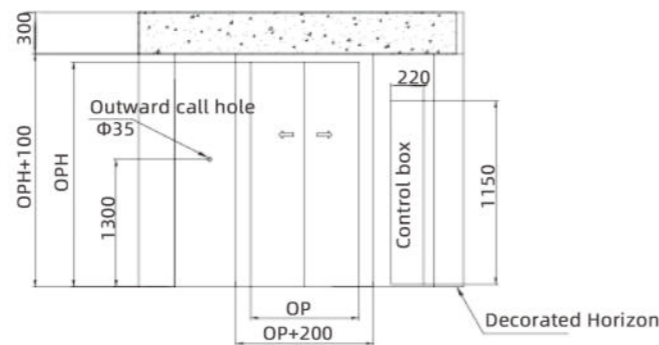

SEJ Home Elevator Basic Technical Specification Table (Traction Type)

Model	Loading (KG)	Speed m/s	Hoistway size HW*HD	Car size CW*CD*CH	Door opening OP*OPH	Top height OH	Pit depth PD
SEJ320-0.4	320	0.4	1600*1450	1000*1100*2200	700*2000	2800	500
SEJ400-0.4	400	0.4	1800*1550	1200*1200*2200	800*2000	2800	500

The schematic drawing of civil work is for reference only

SEJ Strong-drive home elevator construction parameters

Hoistway vertical section

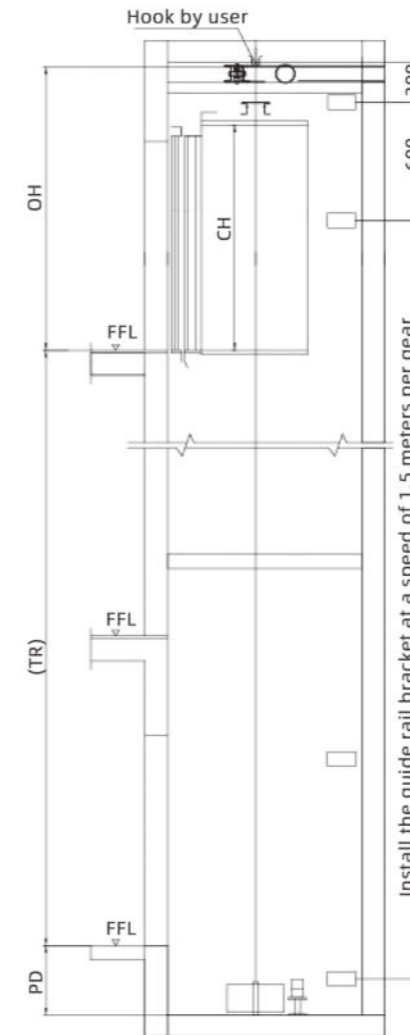

Hoistway plan layout

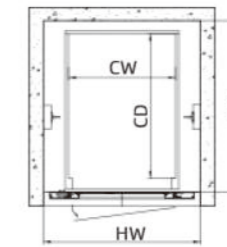

Hoistway plan layout

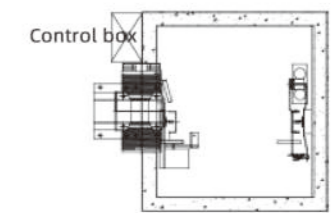

Drawing of reserved holes at inlet and outlet

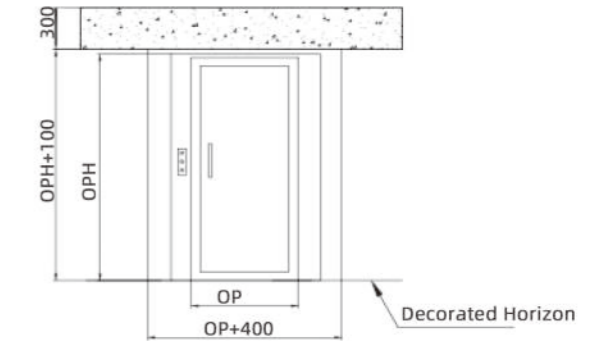

SEJ Home Elevator Basic Technical Specification Table (Strong Drive Manual Swing Door)

Model	Loading (KG)	Speed m/s	Hoistway size HW*HD	Car size CW*CD*CH	Door opening OP*OPH	Top height OH	Pit depth PD
SEJ250-0.3	250	0.3	1100*1250	750*1050*2200	700*2000	2800	350

The schematic drawing of civil work is for reference only

SEJ Belt machine home elevator construction parameters

SEJ Backpack frame home elevator construction parameters

Hoistway vertical section

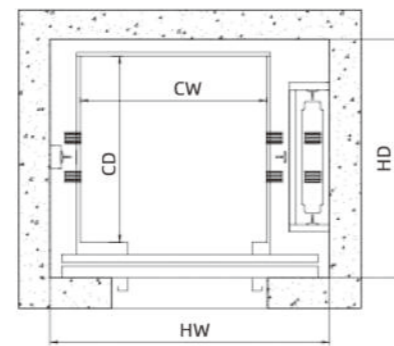
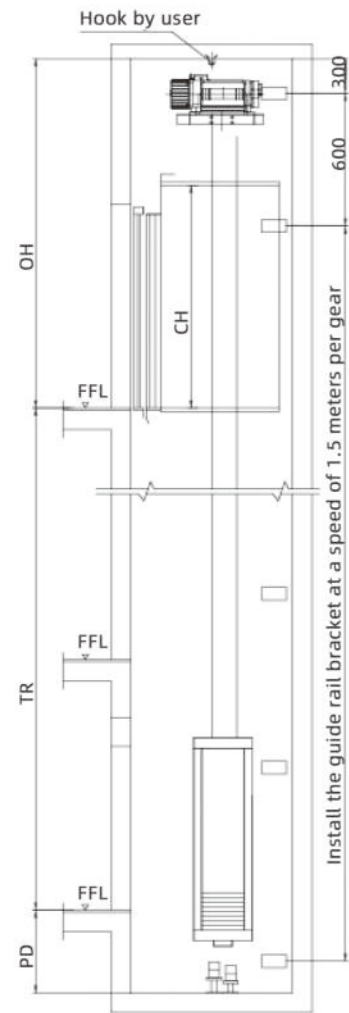

Drawing of reserved holes at inlet and outlet

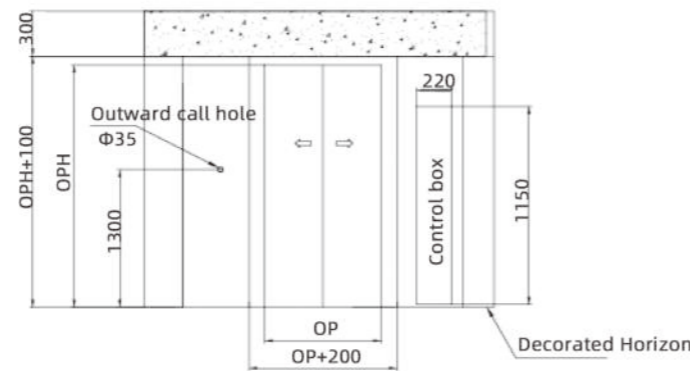

Hoistway vertical section

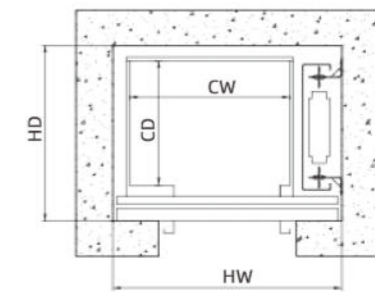
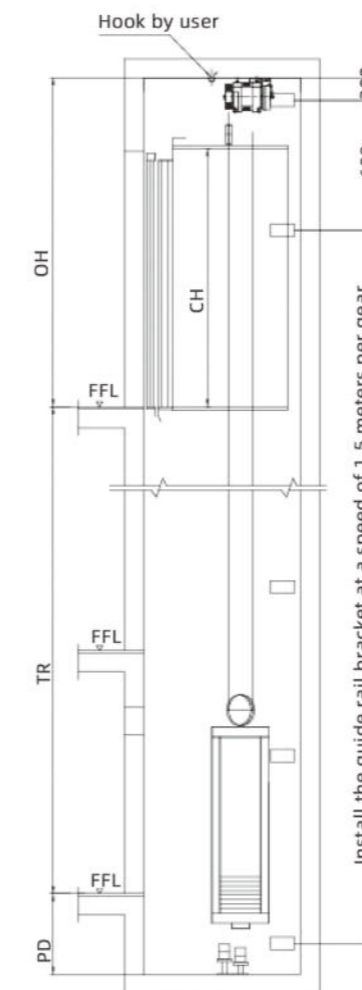

Drawing of reserved holes at inlet and outlet

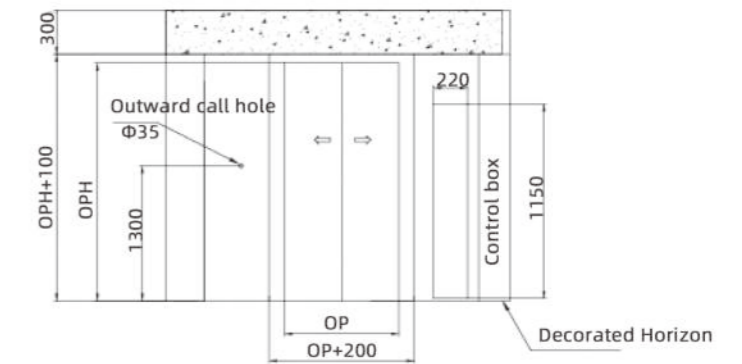

SEJ Home elevator Basic Technical Specification Table (Belt Machine)

Model	Loading (KG)	Speed m/s	Hoistway size HW*HD	Car size CW*CD*CH	Door opening OP*OPH	Top height OH	Pit depth PD
SEJ320-0.4	320	0.4	1600*1450	1000*1100*2200	700*2000	2700	300
SEJ400-0.4	400	0.4	1800*1550	1200*1200*2200	800*2000	2700	300

The schematic drawing of civil work is for reference only

SEJ Home Elevator Basic Technical Specification Table (Backpack Frame)

Model	Loading (KG)	Speed m/s	Hoistway size HW*HD	Car size CW*CD*CH	Door opening OP*OPH	Top height OH	Pit depth PD
SEJ320-0.4	320	0.4	1550*1450	1100*1100*2200	700*2000	3000	300
SEJ400-0.4	400	0.4	1750*1550	1300*1200*2200	800*2000	3000	300

The schematic drawing of civil work is for reference only

Freight elevator Automobile elevator

Freight elevator

Swoda serial freight elevator utilizes micro-computer control technology. It applies high strength section material design to design and manufacture elevator cars. It can transport the goods under various harsh environments. It is safe reliable and durable with high structural intensity smooth operation etc. It is an ideal choice for the factory, warehouse etc. to deliver the goods.

Automobile elevator

Swoda serial automobile elevator applies the well-developed international automobile elevation technology. Automobile elevator has been developed and manufactured through absorbing, transforming and enhancing such advanced international technology. The advanced technology prevents from shaking car, noise due to burdened traction system caused by uneven encountered force to elevator car. It also optimizes the characteristics of the product series.



Freight elevator car decoration



SSC-J060



Ceiling.....Paint steel (Optional color)
Car wall.....Paint steel (Optional color)
Car door.....Paint steel(Optional color)
Floor.....Rifflid plate

SSC-J070



Ceiling.....Hairline stainless steel
Car wall.....Hairline stainless steel
Car doorHairline stainless steel
Floor.....Rifflid plate

Freight elevator car decoration

Operation panel series



CL-D24C
Hairline stainless steel



ST-D19H
Hairline stainless steel
(Without bottom case)



CL-60H-HS
Hairline stainless steel
(Bottom case)

Landing door series



SSE-M070 Standard



SSE-M080 Optional

Option color cards



SEH Freight elevator construction parameters

Hoistway vertical section

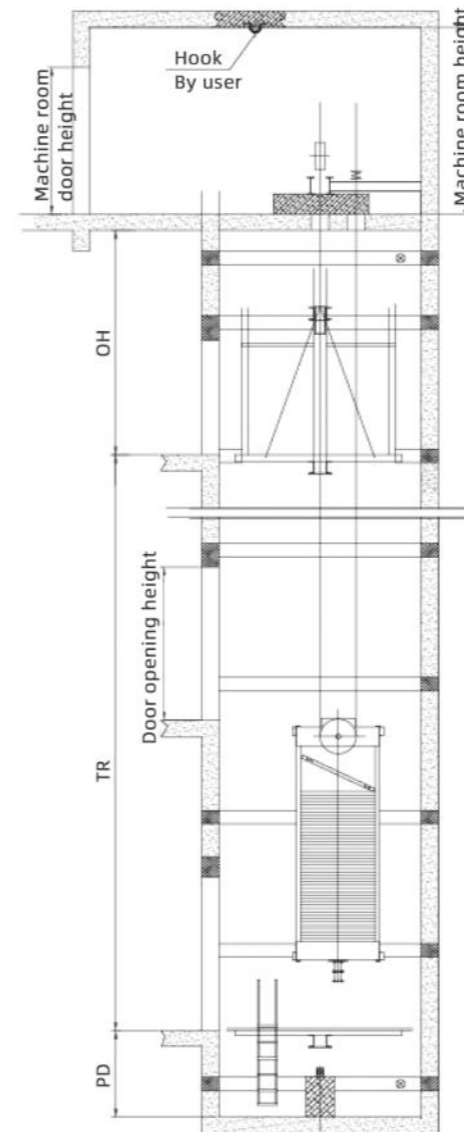

Hoistway plan layout

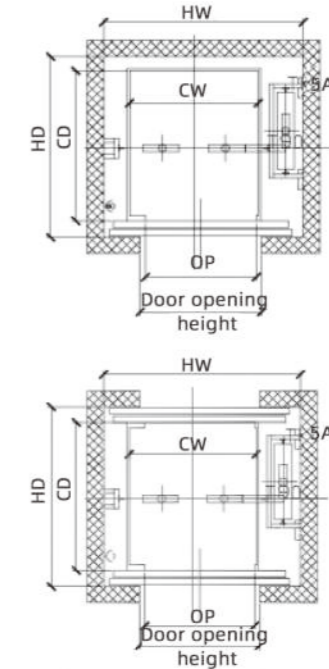

Machine room plan layout

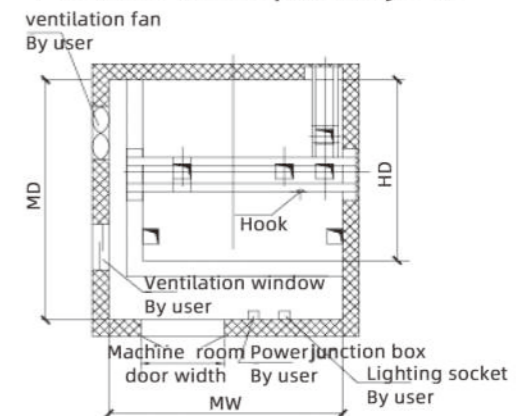

SEH Freight Elevator Basic Technical Specification Table

Model	Loading kg	Speed m/s	Power kw	Car net size(mm)			Hoistway net size(mm)				Max stroke (m)
				CW	CD	OP	HW	HD	PD	OH	
SEH1000-0.5	1000	0.5	11	1400	1700	1000	2300	2050	1400	4300	30
SEH2000-0.5	2000	0.5	11	1850	2250	1500	2800	2750	1400	4300	
SEH2000-0.5	2000	0.5	11	2000	2100	1500	2900	2600	1400	4300	
SEH3000-0.5	3000	0.5	15	2000	2800	1600	3100	3300	1500	4300	
SEH5000-0.5	5000	0.5	22	2600	3400	2200	3900	3900	1600	4800	
SEH8000-0.5	8000	0.5	26.7	2900	4700	2600	4600	5200			
SEH10000-0.5	10000	0.5	33.4	3000	5500	2600	4700	6000	1600	5000	
SEH12000-0.5	12000	0.5	40.5	3100	6350	2600	4800	6850			

The schematic drawing of civil work is for reference only

SEH(MRL) Machine roomless freight elevator construction parameters

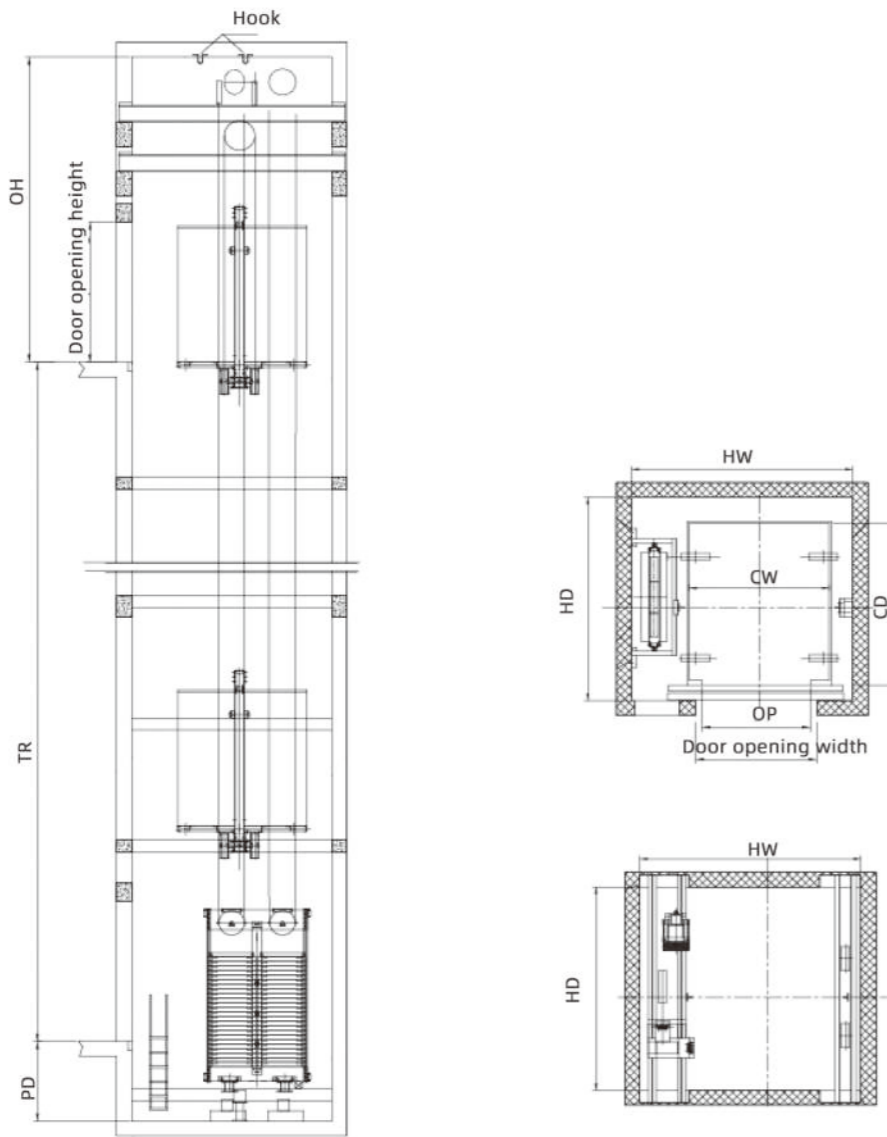

SEH (MRL)Freight Elevator Basic Technical Specification Table

Model	Loading kg	Speed m/s	Power kw	Car net size(mm)			Hoistway net size(mm)				Max stroke (m)
				CW	CD	OP	HW	HD	PD	OH	
SEH(MRL)2000-0.5	2000	0.5	6	1750	2400	1500	2800	2900	1600	4600	30
SEH(MRL)3050-0.5	3050	0.5	10.5	2200	2650	1600	3600	3150	1600	4800	
SEH(MRL)5000-0.5	5000	0.5	16.7	2600	3400	2200	4000	3900	1600	5800	
SEH(MRL)8000-0.5	8000	0.5	26.7	2900	4700	2600	4600	5200	1600	6300	
SEH(MRL)10000-0.5	10000	0.5	33.4	3000	5500	2600	4700	6000			
SEH(MRL)12000-0.5	12000	0.5	40.5	3100	6350	2600	4800	6850			

The schematic drawing of civil work is for reference only

SEA Automobile elevator construction parameters

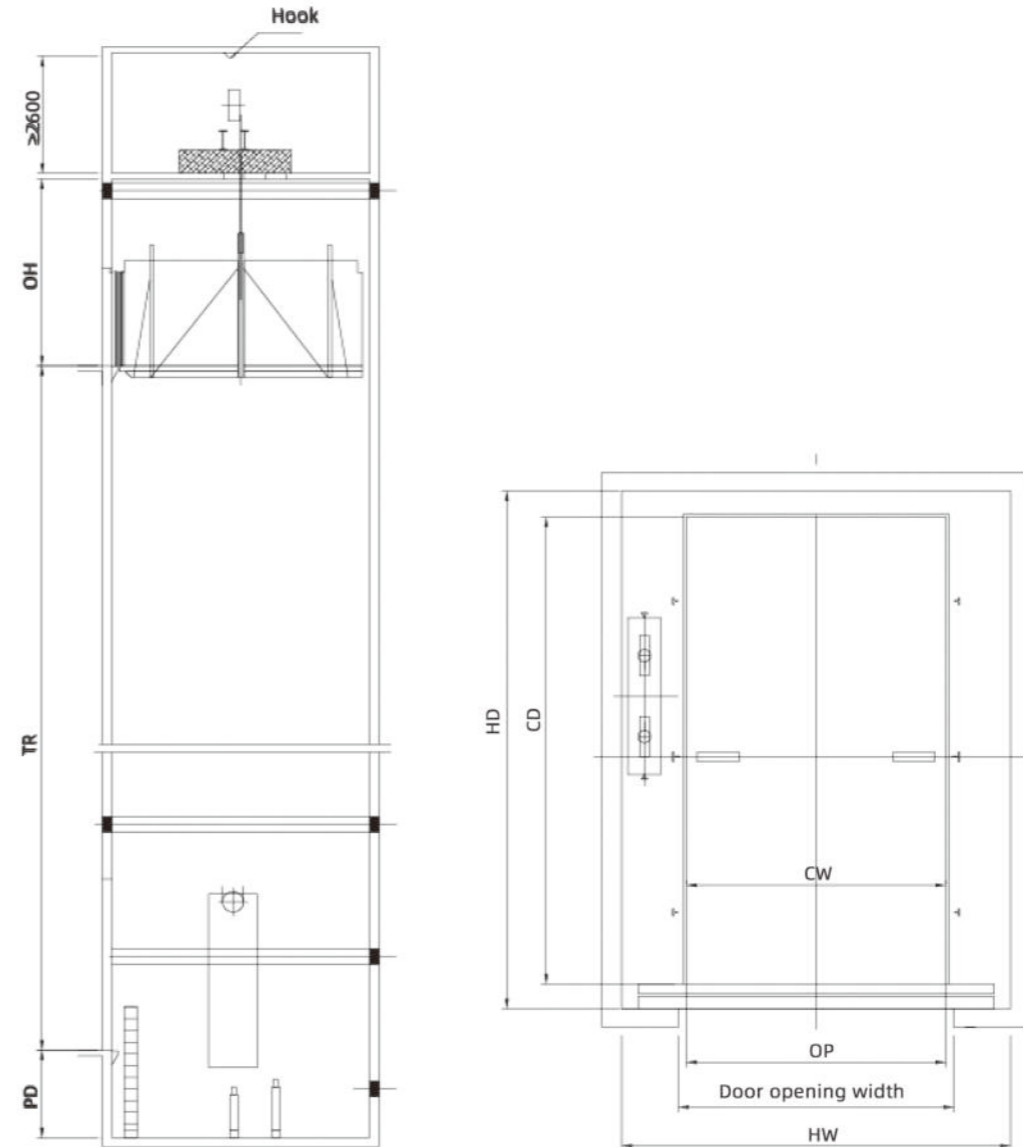

SEA Automobile Elevator Basic Technical Specification Table

Model	Loading kg	Speed m/s	Power kw	Car net size(mm)			Hoistway net size(mm)				Max stroke (m)
				CW	CD	OP	HW	HD	PD	OH	
SEA3000-0.5	3000	0.5	22	2700	5500	2500	4200	6000	1600	5000	30
SEA5000-0.5	5000	0.5	30	3300	7000	2800	4950	7500	1600	5000	

The schematic drawing of civil work is for reference only

Escalator

Smooth delivery

It applies the advanced international technology and combines with top-class design concept. It produces durable Swoda series escalators with smooth operation and low noise. It brings about the brand-new travel experience by fine and exquisite structure, consummate stairway, delicate belt, attractive and charming outline.

Stable and smooth

Novel and popular streamline outline design with full of rhythm shows its noble, grace and remarkable manner. Considerate and eye-catching guide-zone setting is convenient for entry / exit of vast passengers. It applies angle steel truss with tight welding. It enlarges its loading capacity with the more stable and smooth running.



Moving walk

Compact, flexible and relaxing structure

Swoda series moving walk is widely applicable for various concentrated passenger flow areas such as big shopping centers, aviation ports, shopping malls, recreation centers, public facilities etc. The moving walk size has been reduced due to the compact design of guiderail pre-mounting technology, mechanical system and handrail drive system of Swoda series moving walk. It thus effectively utilizes the building space.

Top technology finds the perfect quality

The maximum length of the designed Swoda series inclined sidewalk is 43 meters, the maximum length of the designed horizontal sidewalk is up to 100 meters, and can personalized design according to customer requirements. The use of advanced technology is according with ergonomic design, so that the function of the sidewalk and the performance can be perfect. Novel, fashion and creative streamlined shape design, beautiful appearance, and building harmonious between each other.



SES30° Escalator construction parameters

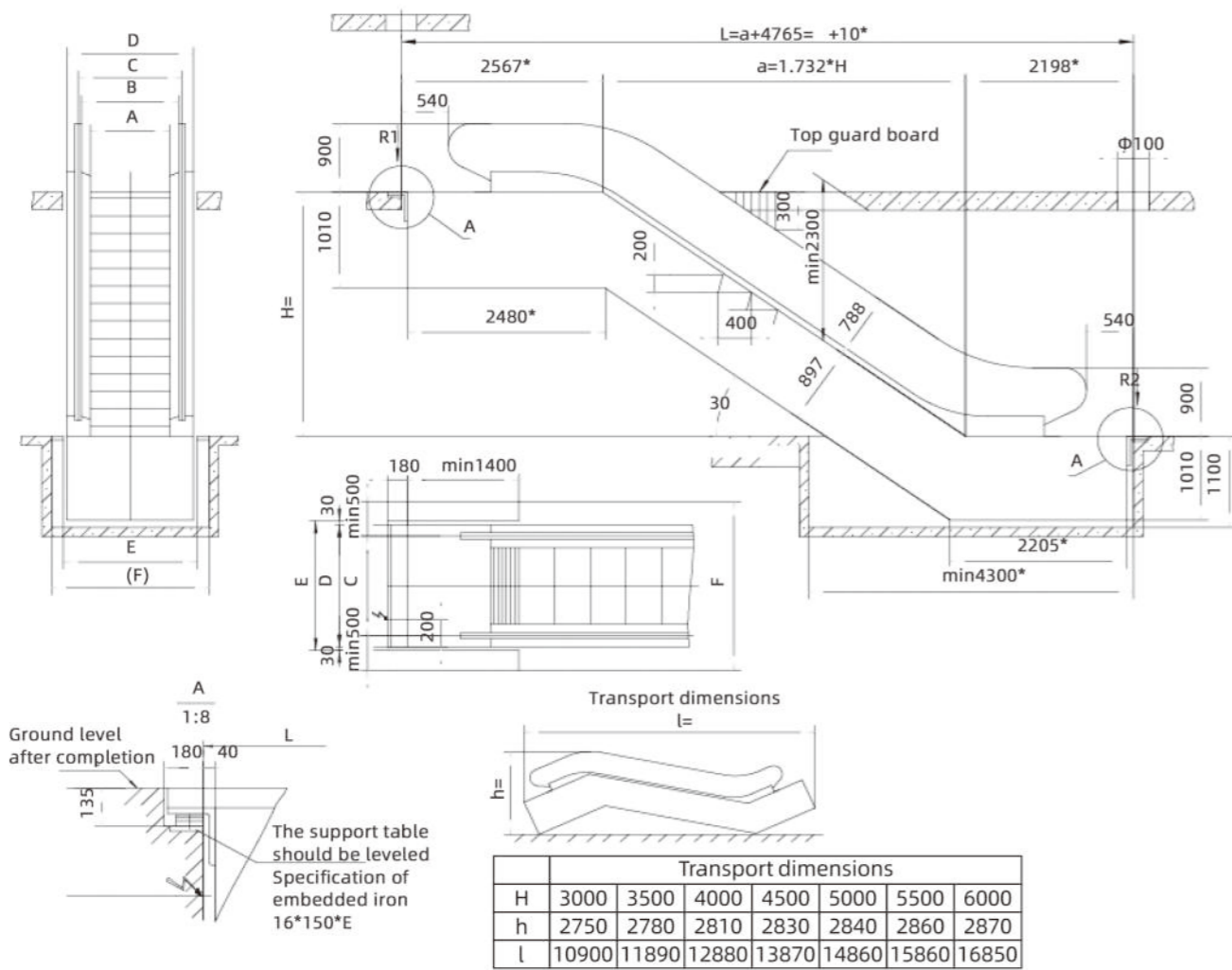

	SES30-600K	SES30-800K	SES30-1000K
A	600	800	1000
B	758	958	1158
C	838	1038	1238
D	1170	1370	1570
E	1250	1450	1650
F	1910	2110	2310
G	18500	16900	15700

1. when the "*" M-type (three horizontal steps) needs to be extended by (490mm).
2. $L > G$ requires intermediate support.
3. The running speed of the escalator is 30m/min.
4. The running speed of the escalator is the same as 35°.

Model	Lifting height (mm)	Net weight (kg)	Supporting force		Power (kW)
			R1(kn)	R2(kn)	
SES30-600K (3600p/h)	3000	5700	46	41	5.5
	3500	6000	49	44	
	4000	6400	52	47	
	4500	6800	56	50	8
	5000	7100	59	53	
	5500	7500	62	56	
SES30-800K (4800p/h)	3000	5900	52	47	5.5
	3500	6300	56	50	
	4000	6700	60	54	
	4500	7100	64	57	8
	5000	7400	68	60	
	5500	8200	74	66	
SES30-1000K (6000p/h)	3000	6300	59	53	8
	3500	6700	64	57	
	4000	7100	68	61	
	4500	7500	73	65	11
	5000	8300	79	71	
	5500	8700	84	75	
	6000	9200	88	79	

The schematic drawing of civil work is for reference only

SES35° Escalator construction parameters

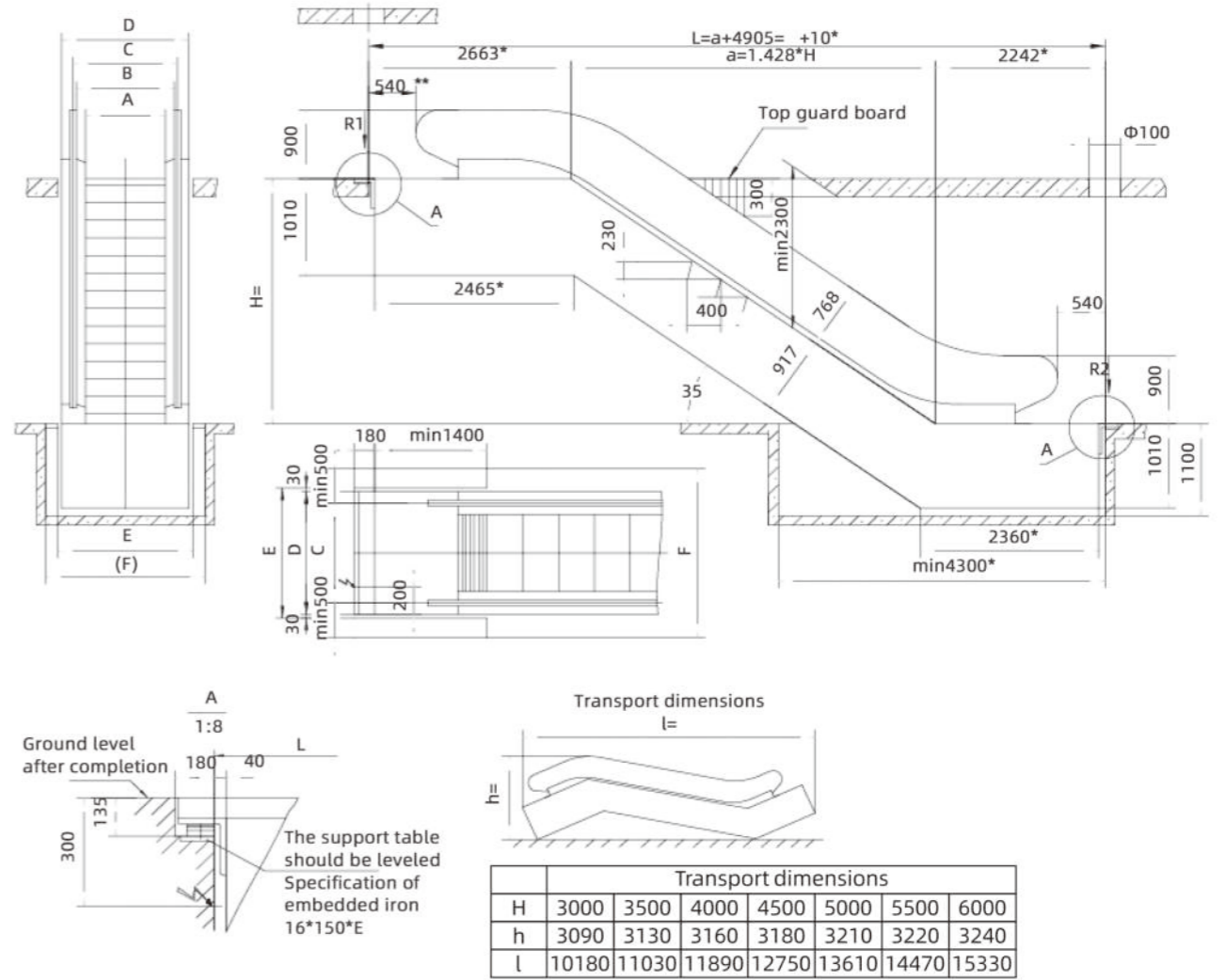

	SES35-600K	SES35-800K	SES35-1000K
A	600	800	1000
B	758	958	1158
C	838	1038	1238
D	1770	1370	1570
E	1250	1450	1650
F	1910	2110	2310
G	18500	16900	75700

1. "*" when M type (three horizontal steps), an extension of 490mm is required.
2. $L > G$ requires intermediate support.
3. The running speed of the escalator is 30m/min.
4. when the step adopts a width of 600, the horizontal section above "*" needs to be extended by 500mm.

Model	Lifting height (mm)	Net weight (kg)	Supporting force		Power (kW)
			R1(kn)	R2(kn)	
SES30-600K (3600p/h)	3000	5400	43	39	5.5
	3500	5700	46	41	
	4000	6000	49	44	
	4500	6400	52	46	8
	5000	6700	54	49	
	5500	7000	57	51	
SES30-800K (4800p/h)	3000	5600	49	44	5.5
	3500	6000	52	47	
	4000	6300	56	50	
	4500	6600	59	53	8
	5000	7000	62	56	
	5500	7300	65	59	
SES30-1000K (6000p/h)	3000	6000	56	50	8
	3500	6400	60	53	
	4000	6700	64	57	
	4500	7100	67	60	11
	5000	7400	71	64	
	5500	8200	77	69	
	6000	8500	81	72	

The schematic drawing of civil work is for reference only

SET0-6° Moving walk construction parameters

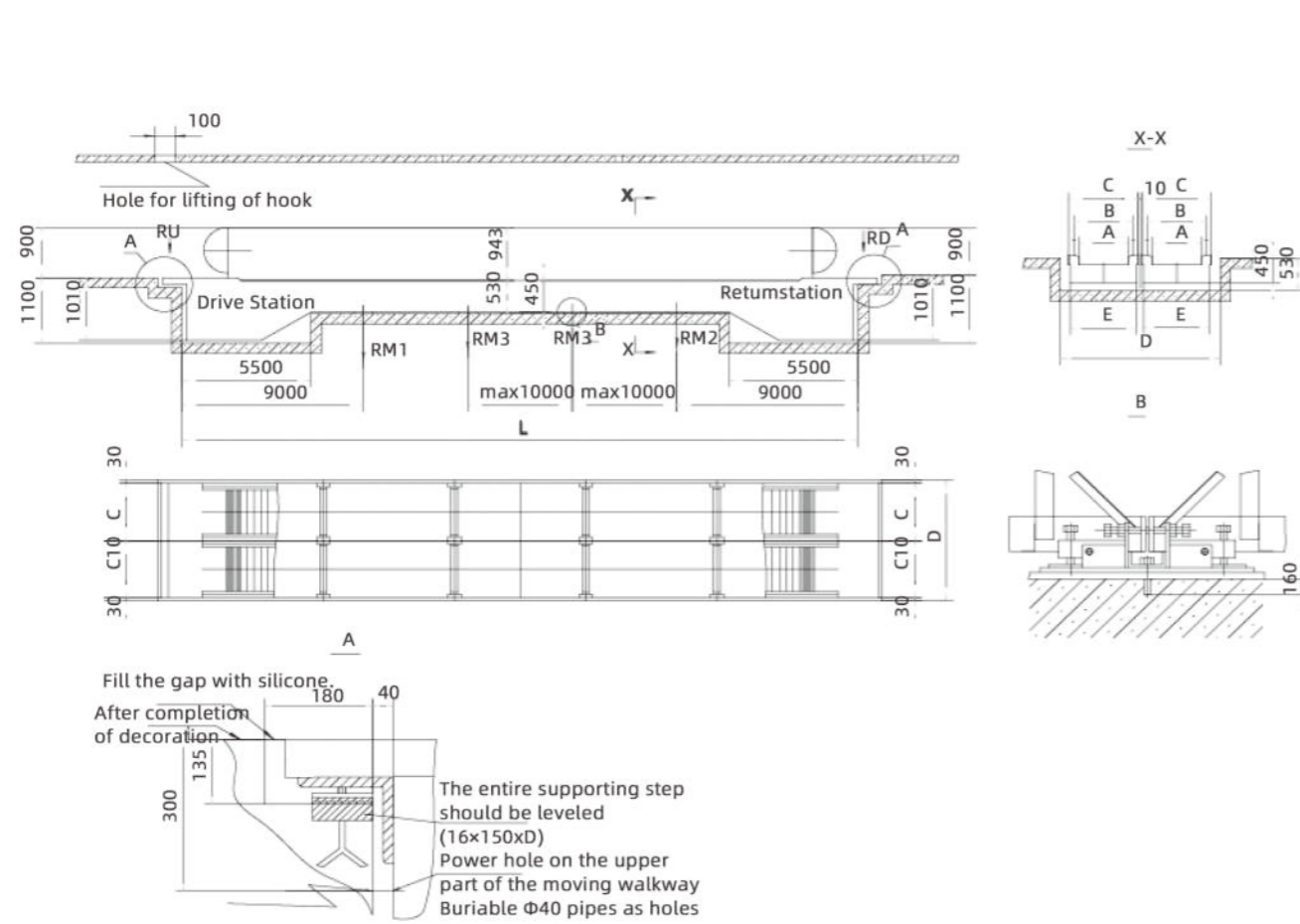

	SET800	SET1000
A	800	1000
B	1110	1310
C	1370	1570
D	2870	3270
E	1300	1500

Speed (m/s)	0.5		0.65		0.75	
width (mm)	800	1000	800	1000	800	1000
power (Kw)	Maximum conveying length (m)					
5.5	84	73	71	61	65	55
8	124	107	104	89	95	87
11	150	150	150	139	147	125
15				150	150	150

1. Conveying length L size according to user needs.
2. RD, RU, and RM support forces were consulted with Swoda when signing the contract.

SET10-12° Moving walk construction parameters

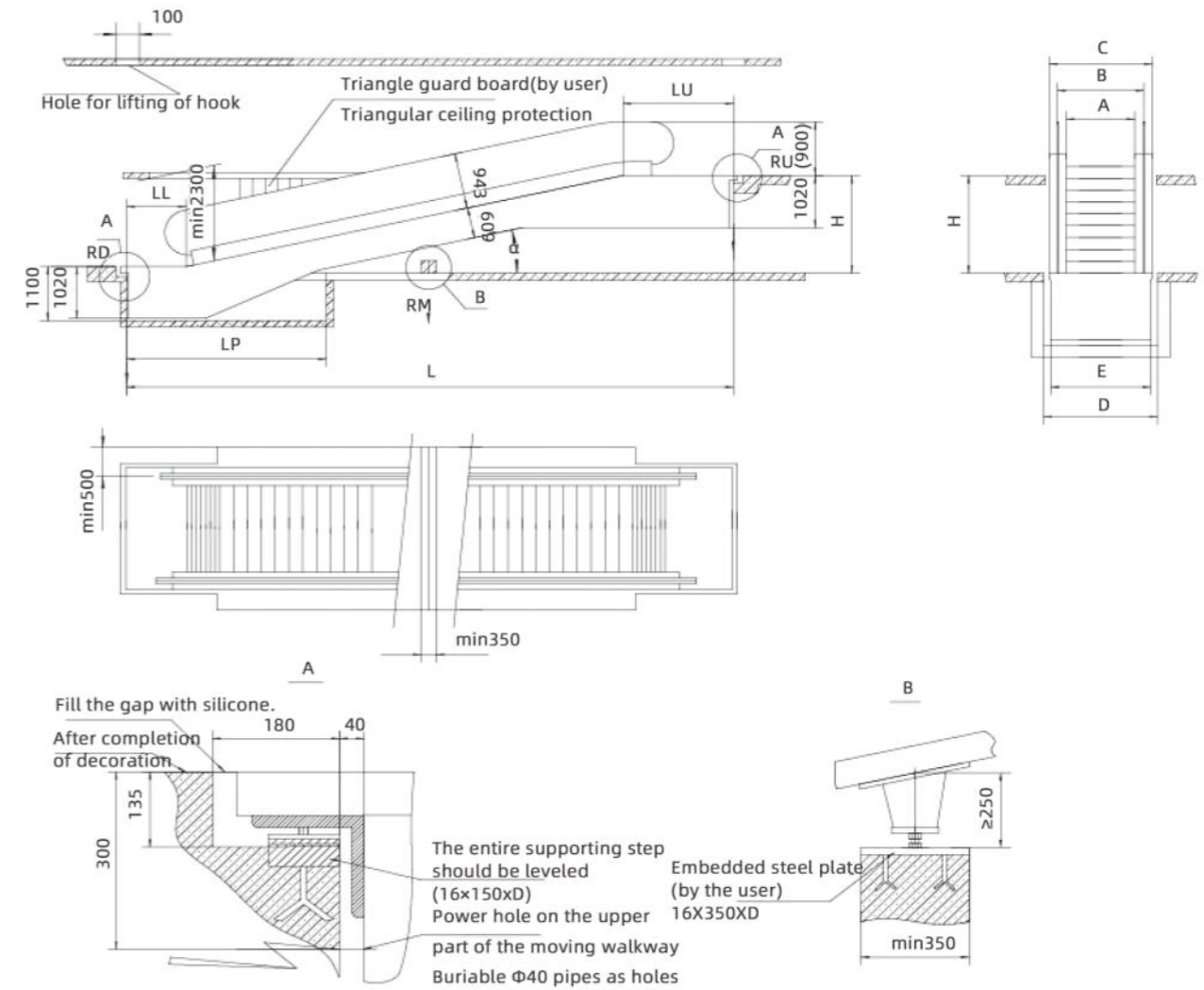

Specifications (A)	B	c	D	E	K1	K2
SET1000	1238	1570	1650	1500	15000	30000
SET800	1038	1370	1450	1300	16300	32600

angle of roll α	10°	11°	12°
Lu	1983	2023	2118
LL	1043	1054	1012
LP	4500	4300	4000
L	5.6713xH+3026	5.1446xH+3077	4.7046x(H-17)+3130

1. when $L > K1$, one intermediate support is required, with the position basically centered.
when $L > K2$, 2 intermediate supports are required, with the positions basically evenly distributed.
2. Please consult Swoda for support forces for RD, RU, RM.

The creditable and professional services

Relying on the first-class technology, rich managing experience and superior services, Swoda Elevator scientifically maintains the products and makes the strict quality supervision. welcome to choose Swoda elevator in order to get a full set of the complete service systems.

After-sales service

The professional service contents

Regarding the worn parts and aged out system, "mainly taking precaution measures, pre-inspection, pre-repair" keeps the valuable key parts, adds accessory hardware or systematic renewal.

The skillful repair and maintenance group goes through the professional technical training

They are rich in experience and advanced in craft& tech. They are considerate to the clients requirements and provide the clients with whole hearted services.

Standard service quality

It persists in human-centered principle. It regularly provides the first-line service team with the skill and safety training. It enhances the capability of first-line servicemen, construct a superior service team.

Ample parts, prompt and convenient storage and delivery

The powerful Parts Center most strongly guarantees the material supply in the service system. Storage & Delivery Center quickly and wonderful coordinates with Parts Center. Therefore our clients can enjoy the rapid and convenient services within the shortest time .

